



NUMBER: 03-004-07

GROUP: Differential &
Driveline

DATE: December 19, 2007

This bulletin is supplied as technical information only and is not an authorization for repair. No part of this publication may be reproduced, stored in a retrieval system, or transmitted, in any form or by any means, electronic, mechanical, photocopying, or otherwise, without written permission of Chrysler LLC.

SUBJECT:

Ringing Sound Coming From Propeller Shaft When Transmission Is Shifted From Drive To Reverse Or Reverse To Drive

OVERVIEW:

This bulletin involves replacing transmission output flange on certain vehicles and applying "Stud N Bearing Mount Adhesive" to the transmission output shaft flange splines.

MODELS:

2007	(KA)	Nitro
2007	(L2)	300C (China)
2006 - 2007	(LE)	300/300 Touring (International Markets)
2005 - 2007	(LX)	300/Magnum/Charger
2005 - 2007	(WH)	Grand Cherokee (International Markets)
2005 - 2007	(WK)	Grand Cherokee
2006 - 2007	(XH)	Commander (International Markets)
2006 - 2007	(XK)	Commander

NOTE: This bulletin only applies to RWD vehicles equipped with NAG1 transmission (W5A580, sales code DGJ).

SYMPTOM/CONDITION:

A ringing, snapping or popping sound may be heard coming from the drive line when the transmission is shifted from forward to reverse or reverse to forward. The sound may also occur when the brakes are released after shifting into or out of Drive or Reverse.



Stick with the Specialists™

DIAGNOSIS:

Start the vehicle, apply the park brake and shift the transmission from forward to reverse and back with the brakes applied. If the sound is present, perform the Repair Procedure.

PARTS REQUIRED:

Qty.	Part No.	Description
1	04318032	Stud N' Bearing Mount Adhesive.
1	52108234AA	Nut-Collar Double Hex
1(AR)	05175566AA	Output Flange (3.5L)
1(AR)	52108628AB	Output Flange (3.7L)
1(AR)	05135158A	Output Flange (5.7L)
1(AR)	05170003AB	Output Flange (6.1L)

SPECIAL TOOLS/EQUIPMENT REQUIRED:

C-3281	Flange Holder
8992	Flange Puller
9078	Staking Tool
C-4171	Drive Handle

REPAIR PROCEDURE:

CAUTION: Mark the propeller shaft in relation to the transmission and axle flanges prior to removal.

1. Remove propeller shaft: refer to the detailed removal procedures available in DealerCONNECT > TechCONNECT under: Service Info > 3 - DIFFERENTIAL & DRIVELINE > PROPELLER SHAFT > REMOVAL

2. Using Special tools C-3281 and 8992, remove the transmission output shaft nut and remove the flange([Fig. 1](#)).

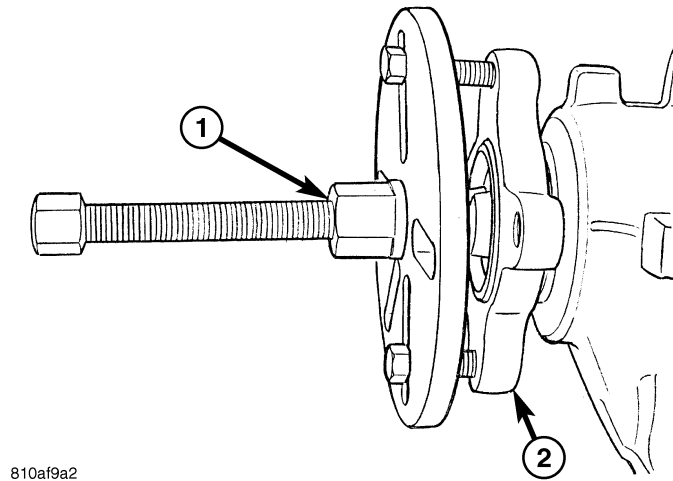

Fig. 1 FLANGE PULLER

- 1 - FLANGE PULLER #8992
- 2 - PINION FLANGE

-
3. Is your vehicle one of the vehicle/engine configurations listed below?
 - a. Yes >>> Proceed to [Step #4](#).
 - b. No >>> Proceed to [Step #5](#)
 - 2005 LX 5.7L built prior to August 18, 2004
 - 2005 LX 6.1L or WK 3.7L built prior to June 22, 2005
 - 2006 LX 3.5L built prior to June 22, 2005
 4. Replace output flange with corresponding part number in Parts Table above.
 5. Clean the splines on the output shaft and the output flange and apply a thin coating of MOPAR Stud N' Bearing Mount Adhesive, p/n 04318031 or equivalent, to the splines of the output flange.
 6. Install the flange and tighten the nut to 200 Nm (150 ft. lbs.).
 7. Stake the nut using 9078 staking tool and C-4171 drive handle.
 8. Install propeller shaft: refer to the detailed installation procedures available in DealerCONNECT > TechCONNECT under: Service Info > 3 - DIFFERENTIAL & DRIVELINE > PROPELLER SHAFT > INSTALLATION.

POLICY:

Reimbursable within the provisions of the warranty.

TIME ALLOWANCE:

Labor Operation No:	Description	Amount
21-15-02-90	Replace Transmission Flange On Certain Vehicles And Apply Adhesive To Transmission Flange	LX/LE/L2 1.3 Hrs. KA/WK/WH/ XK/XH 0.6 Hrs.

FAILURE CODE:

68	Noisy
----	-------